

English – January 2017

Introduction

This Installation Guide provides instructions for installation, startup and adjustment. To receive a copy of the Instruction Manual, contact your local Sales Office or view a copy at www.fisher.com. For further information refer to MR95 Series Industrial Pressure Regulators Instruction Manual, D103587X012.

P.E.D. Category

This product may be used as a safety accessory with pressure equipment in the following Pressure Equipment Directive. It may also be used outside of the Pressure Equipment Directive using Sound Engineering Practice (SEP) per table below. For information on the current PED revision see Bulletin: [D103053X012](#).

TYPE	PRODUCT SIZE	BODY MATERIAL	CATEGORY
MR95L/ MR95LD	1/4 NPT, DN 15 to 25 / 1/2 to 1 in.	All	SEP
MR95H/ MR95HD	1/4 NPT, DN 15 to 25 / 1/2 to 1 in.	All	SEP
	DN 40 and 50 / 1-1/2 and 2 in.	Cast iron Steel and Stainless steel	I II
MR95HP/ MR95HT/ MR95HDP	1/4 NPT, DN 15 to 25 / 1/2 to 1 in.	All	SEP
	DN 40 and 50 / 1-1/2 and 2 in.	Steel and Stainless steel	II

Specifications

Available Constructions

Type MR95L: Pressure reducing regulator for outlet pressures from 0.14 to 2.1 bar / 2 to 30 psig. 1/4 to 1 in. body sizes only.

Type MR95H: Pressure reducing regulator for outlet pressures from 0.34 to 10.3 bar / 5 to 150 psig.

Type MR95HP: Pressure reducing regulator for outlet pressures from 1.0 to 27.6 bar / 15 to 400 psig (soft-seated).

Type MR95HT: High temperature pressure reducing regulator for outlet pressures from 1.0 to 20.7 bar / 15 to 300 psig (metal seat) and up to 343°C / 650°F.

Type MR95LD: Pressure reducing differential regulator for differential set pressures from 0.14 to 2.1 bar / 2 to 30 psi with maximum inlet pressure up to 20.7 bar / 300 psi and maximum outlet pressure up to 8.6 bar / 125 psi. 1/4 to 1 in. body sizes only.

Type MR95HD: Pressure reducing differential regulator for differential set pressures from 0.34 to 10.3 bar / 5 to 150 psi with maximum inlet/outlet pressures up to 20.7 bar / 300 psig.

Type MR95HDP: Pressure reducing differential regulator for differential set pressures from 0.34 to 10.3 bar / 5 to 150 psi with maximum inlet/outlet pressures up to 41.4 bar / 600 psi.

Body and Orifice Sizes

1/4 NPT body: 7.22 mm / 0.284 in. orifice

DN 15 / 1/2 in. body: 10.56 mm / 0.416 in. orifice

DN 20 and 25 / 3/4 and 1 in. bodies: 16.02 mm / 0.631 in. orifice

DN 40 and 50 / 1-1/2 and 2 in. bodies (not available for

Types MR95L and MR95LD): 29 mm / 1.142 in. orifice

End Connection Styles

NPT, SWE and Welded and Integral CL150 RF, CL300 RF, CL600 RF and PN 16/25/40 RF; all sizes are fabricated with slip-on flanges (for welded end connections) and are EN flanged 356 mm face-to-face (14 in. face-to-face)

Outlet and Differential Pressure Ranges⁽¹⁾

See Table 1

Maximum Spring Case Loading Pressure for Types MR95LD, MR95HD and MR95HDP

See Table 2

Monel® is a mark owned by Special Metals Corporation.
Hastelloy® C is a mark owned by Haynes International, Inc.

1. The pressure/temperature limits in this Installation Guide and any applicable standard or code limitation should not be exceeded.

2. The pressure limits given are based on the body size and body materials only. Actual pressure limits of the assembled regulator may decrease and vary depending on the temperature, body end connection, diaphragm, seat and/or trim material of the regulator.

Maximum Cold Working Pressures of Body Size and Materials⁽¹⁾⁽²⁾

See Table 2

Pressure Registration

Internal or External

Temperature Capabilities⁽¹⁾

See Table 3

Shutoff Classification Per ANSI/FCI 70-3-2004

Metal Seats: Class IV

PTFE: Class IV

Elastomer Seats: Class VI or better

API 614 Compliant

Steel or Stainless steel constructions with Stainless steel trim meet API 614 Requirements.

Sour Gas Service Capability

Optional materials are available for applications handling sour gases. These constructions comply with the recommendations of NACE International Standards MR0175-2002 and MR0103. Optional materials are available to meet ANSI/NACE MR0175/ISO 15156.

Installation



Only qualified personnel shall install or service a regulator. Regulators should be installed, operated and maintained in accordance with international and applicable codes and regulations and Emerson Process Management Regulator Technologies, Inc. instructions.

If the regulator vents fluid or a leak develops in the system, it indicates that service is required. Failure to take the regulator out of service immediately may create a hazardous condition.

Personal injury, equipment damage or leakage due to escaping fluid or bursting of pressure containing parts may result if this regulator is overpressured or is installed where service conditions could exceed the limits given in the Specifications section or where conditions exceed any ratings of the adjacent piping or piping connections.

To avoid such injury or damage, provide pressure-relieving or pressure-limiting devices (as required by the appropriate code, regulation or standard) to prevent service conditions from exceeding limits.

Additionally, physical damage to the regulator could result in personal injury and property damage due to escaping fluid. To avoid such injury and damage, install the regulator in a safe location.

Clean out all pipelines before installation of the regulator and check to be sure the regulator has not been damaged or has collected foreign material during shipping. For NPT bodies, apply pipe compound to the external pipe threads. For flanged bodies, use suitable line gaskets and approved piping and bolting practices. Install the regulator in any position desired, unless otherwise specified, but be sure flow through the body is in the direction indicated by the arrow on the body.

Note

It is important that the regulator be installed so that the vent hole in the spring case is unobstructed at all times. For outdoor installations, the regulator should be located away from vehicular traffic and positioned

MR95 Series

Table 1. Outlet and Differential Pressure Ranges

TYPE	BODY SIZE		OUTLET OR DIFFERENTIAL PRESSURE RANGE ⁽¹⁾	
	DN	In.	bar	psi/psig
MR95L and MR95LD	15, 20 and 25	1/4 NPT, 1/2, 3/4 and 1	0.14 to 0.41	2 to 6
			0.34 to 1.0	5 to 15
			0.90 to 2.1	13 to 30
MR95H, MR95HD and MR95HDP	15, 20 and 25	1/4 NPT, 1/2, 3/4 and 1	1.0 to 2.1	15 to 30
			1.7 to 5.2	25 to 75
			4.8 to 10.3	70 to 150
	40 and 50	1-1/2 and 2	0.34 to 5.5	5 to 80
			4.1 to 8.3	60 to 120
			6.9 to 9.7	100 to 140
			8.3 to 10.3	120 to 150
			0.34 to 4.1	5 to 60
			3.4 to 8.3	50 to 120
MR95HT	15, 20 and 25	1/4 NPT, 1/2, 3/4 and 1	1.0 to 6.9	15 to 100
			5.5 to 20.7	80 to 300
	40 and 50	1-1/2 and 2	1.0 to 6.9	15 to 100
MR95HP	15, 20 and 25	1/4 NPT, 1/2, 3/4 and 1	4.1 to 17.9	60 to 260
			1.0 to 6.9	15 to 100
	40 and 50	1-1/2 and 2	5.5 to 27.6	80 to 400
			1.0 to 6.9	15 to 100
			4.1 to 20.7	60 to 300

1. For Types MR95LD, MR95HD and MR95HDP regulators, the pressure ranges indicate the differential pressure that can be obtained with the indicated spring. The differential pressure (spring setting) is added to the spring case loading pressure to determine the actual outlet pressure.

Table 2. Maximum Cold Working Pressures of Body Size and Material⁽¹⁾⁽²⁾

TYPE	BODY SIZE	BODY MATERIALS	MAXIMUM INLET PRESSURE		MAXIMUM OUTLET PRESSURE		MAXIMUM SPRING CASE PRESSURE	
			bar	psig	bar	psig	bar	psig
MR95L/ MR95LD	All available sizes	Gray Cast Iron	17.2	250	3.4	50	3.4	50
		WCC/LCC Steel; CF8M/CF3M Stainless Steel; Monel [®] ; Hastelloy [®] C ⁽³⁾	20.7	300	8.6	125	8.6	125
MR95H/ MR95HD	All available sizes	Gray Cast Iron	17.2	250	17.2	250	17.2	250
		WCC/LCC Steel; CF8M/CF3M Stainless Steel; Monel [®] ; Hastelloy [®] C ⁽³⁾ ; Aluminum-Bronze ⁽³⁾	20.7	300	20.7	300	20.7	300
MR95HDP	All available sizes	WCC/LCC Steel	41.4	600	41.4	600	41.4	600
		CF8M/CF3M Stainless Steel; Monel [®] ; Hastelloy [®] C ⁽³⁾ ; Aluminum-Bronze ⁽³⁾	41.4	600	37.9	550	37.9	550
MR95HP	All available sizes	WCC/LCC Steel	68.9	1000	41.4	600	41.4	600
		CF8M/CF3M Stainless Steel; Monel [®] ; Hastelloy [®] C ⁽³⁾ ; Aluminum-Bronze ⁽³⁾	68.9	1000	37.9	550	37.9	550
MR95HT	1/4 NPT and DN 15 to 25 / 1/2 to 1 in.	WCC/LCC Steel	41.4	600	41.4	600	41.4	600
		CF8M/CF3M Stainless Steel; Monel [®] ; Hastelloy [®] C ⁽³⁾ ; Aluminum-Bronze ⁽³⁾	41.4	600	37.9	550	37.9	550
	DN 40 and 50 / 1-1/2 and 2 in.	WCC/LCC Steel; CF8M/CF3M Stainless Steel; Monel [®] ; Hastelloy [®] C; Aluminum-Bronze	41.4	600	31.0	450	31.0	450

1. The pressure/temperature limits in this Installation Guide and any applicable standard or code limitation should not be exceeded.
 2. The pressure limits given are based on the body size and body materials only. Actual pressure limits of the assembled regulator may decrease and vary depending on the temperature, body end connection, diaphragm, seat and/or trim material of the regulator.
 3. Not available for 1/4 NPT body size.

Table 3 MR95 Series Temperature Capabilities⁽¹⁾⁽²⁾

TRIM MATERIAL	SEAT	DIAPHRAGM	O-RING	DIAPHRAGM PROTECTOR	GASKET	TEMPERATURE	
						°C	°F
Nitrile (NBR)	✓		✓			-40 to 82	-40 to 180
Neoprene (CR)		✓				-40 to 82	-40 to 180
Fluorocarbon (FKM) ⁽³⁾	✓	✓	✓			-18 to 149, Limited to 93°C for hot water	0 to 300, Limited to 200°F for hot water
Ethylenepropylene (EPDM)	✓	✓	✓			-7 to 135	20 to 275
Perfluoroelastomer (FFKM)	✓		✓			-18 to 218	0 to 425
PTFE	✓			✓		-40 to 204	-40 to 400
Metal	✓	✓				-40 to 343	-40 to 650
Composition					✓	-40 to 204, Limited to 149°C for steam	-40 to 400, Limited to 300°F for steam
Graphite					✓	-40 to 343	-40 to 650
BODY MATERIAL						TEMPERATURE	
						°C	°F
Gray cast iron						-29 to 208	-20 to 406
WCC Steel ⁽⁴⁾						-29 to 343	-20 to 650
LCC Steel ⁽⁴⁾						-40 to 343	-40 to 650
Stainless steel ⁽⁴⁾ , Monel [®] or Hastelloy [®] C						-40 to 288	-40 to 550
Aluminum-Bronze						-40 to 260	-40 to 500

1. The pressure/temperature limits in this Installation Guide and any applicable standard limitation should not be exceeded.
 2. The temperature limits given are based on the body size and body materials only. Actual temperature limits of the assembled regulator may decrease and vary depending on the body end connection, diaphragm, seat and/or trim material of the regulator.
 3. Not for use on steam service.
 4. Meets API 614 requirements (with Stainless steel trim).

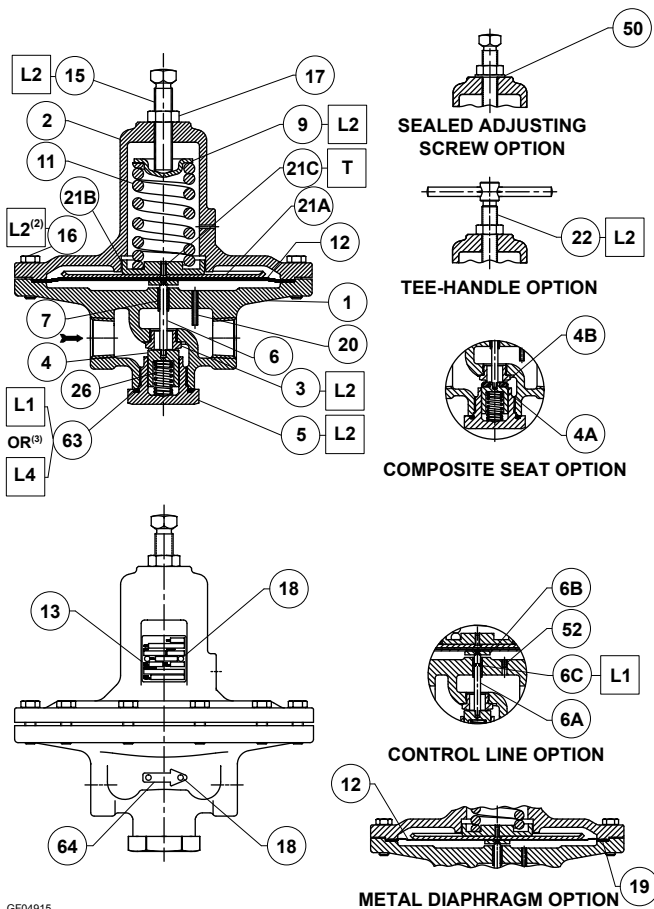

GF04915

- APPLY LUBRICANT OR SEALANT⁽¹⁾;
 T = THREAD LOCKER
 L1 = GENERAL PURPOSE PTFE OR LITHIUM GREASE
 L2 = ANTI-SEIZE COMPOUND
 L4 = GRAPHITE SEALANT

Figure 1. Type MR95L, 1/4 NPT and DN 15 to 25 / 1/2 to 1 In. Body Sizes Assembly

so that water, ice and other foreign materials cannot enter the spring case through the vent. Avoid placing the regulator beneath eaves or downspouts and be sure it is above the probable snow level.

Overpressure Protection

The recommended pressure limitations are stamped on the regulator nameplate. Some type of overpressure protection is needed if the actual inlet pressure exceeds the maximum operating outlet pressure rating. Overpressure protection should also be provided if the regulator inlet pressure is greater than the safe working pressure of the downstream equipment.

Regulator operation below the maximum pressure limitations does not preclude the possibility of damage from external sources or debris in the line. The regulator should be inspected for damage after any overpressure condition.

Startup

The regulator is factory set at approximately the midpoint of the spring range or the pressure requested, so an initial adjustment may be required to give the desired results. With proper installation completed and relief valves properly adjusted, slowly open the upstream and downstream shutoff valves.

*Recommended Spare Part

- Lubricants and sealants must be selected such that they meet the temperature requirements.
- Apply L2 (anti-seize compound) on key 16 for Stainless steel bolts.
- Apply L4 (graphite sealant) instead of L1 (general purpose PTFE or lithium grease) on key 63 for graphite ring.

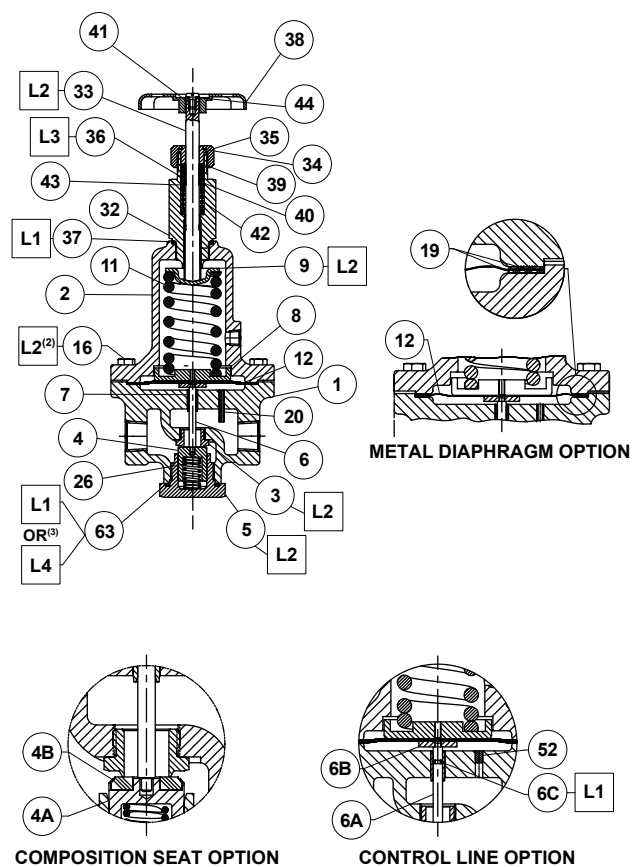

GF04918

- APPLY LUBRICANT⁽¹⁾;
 L1 = GENERAL PURPOSE PTFE OR LITHIUM GREASE
 L2 = ANTI-SEIZE COMPOUND
 L4 = GRAPHITE SEALANT

Figure 2. Types MR95HD and MR95HDP, 1/4 NPT and DN 15 to 50 / 1/2 to 2 In. Body Sizes Assembly

Adjustment

To change the outlet pressure, loosen the jam nut and turn the adjusting screw clockwise to increase outlet pressure or counterclockwise to decrease it. Monitor the outlet pressure with a test gauge during the adjustment. Tighten the jam nut to maintain the desired setting.

Taking Out of Service (Shutdown)



To avoid personal injury resulting from sudden release of pressure, isolate the regulator from all pressure before attempting disassembly.

Parts List

Key	Description
1	Body
2	Spring Case
3*	Orifice
4*	Valve Plug, Metal seat
4*	Disk Holder Assembly, Composition seat
4a	Disk Holder
4b	Disk
4c	O-ring (not shown)
5	Valve Plug Guide
6	Stem/Stem Assembly

MR95 Series

Parts List (continued)

Key Description

- 6a Stem
- 6b Pusher Plate
- 6b O-ring
- 6c O-ring
- 7 Stem Guide Bushing
- 8 Lower Spring Seat
- 9 Upper Spring Seat
- 10 Pusher Post, (not shown)
- 11 Control Spring
- 12* Diaphragm (2 required for metal, FKM and EPDM diaphragms)⁽¹⁾
- 13 Nameplate
- 14* Diaphragm Protector (not shown)
- 15 Adjusting Screw
- 16 Cap Screw
 - Types MR95L and MR95LD
 - DN 15 / 1/4 NPT and 1/2 in. bodies - 10 required
 - DN 20 and 25 / 3/4 and 1 in. bodies - 12 required
 - Types MR95H and MR95HD
 - 1/4 NPT Body - 6 required
 - DN 15 to 50 / 1/2 to 2 in. bodies - 8 required
 - Types MR95HP, MR95HDP and MR95HT
 - 1/4 NPT Body - 6 required
 - DN 15 to 50 / 1/2 to 2 in. bodies - 8 required
- 17 Jam Nut
- 18 Nameplate Drive Screw (4 required)
- 19* Diaphragm Gasket (2 required for pressure loaded spring case)
- 20 Pitot Tube (for constructions without control line)
- 21 Diaphragm Head Assembly (not shown)
- 21a Diaphragm Head
- 21b Lower Spring Seat
- 21c Screw
- 21 Diaphragm Head (2 required) (not shown)
- 22 Adjusting Screw Assembly (Tee Handle Adjustment)
- 23 Handwheel (not shown)

Key Description

- 26 Inner Valve Spring
- 27 Inner Valve Base (not shown)
- 27 Inner Valve Base Assembly (not shown)
- 29* Gasket (2 required) (not shown)
- 31 Locknut (not shown)
- 32 Stuffing Box
- 33 Adjusting Screw
- 34 Packing Follower
- 35 Stuffing Box Nut
- 36 Packing (3 required)
- 37* Stuff Box Gasket
- 38 Handwheel/Handle
- 39 Internal Adaptor
- 40 External Adaptor
- 41 Machine Screw
- 41 Jam Nut
- 42 Spring
- 43 Washer
- 44 Washer
- 45* O-ring (2 required for Types MR95HD and MR95HDP only) (not shown)
- 47 NACE Tag (not shown)
- 48 Tag Wire (not shown)
- 49 Lockwasher (not shown)
- 50* Sealing Washer
- 51 Vent, Type Y602-12 (not shown)
- 52 Plug
- 62 Adaptor (Types MR95L and MR95LD:
 - 2 gauges - 2 required; 1 gauge - 1 required) (not shown)
- 63* Bottom Plug Seal
- 64 Flow Arrow
- 65 Pipe Plug (not shown)
- 66 Inlet Pressure Gauge (not shown)
- 67 Outlet Pressure Gauge (not shown)
- 69 ATEX Tag (not shown)
- 70 PED Tag (not shown)

*Recommended Spare Part

1. Only one metal diaphragm is needed for Types MR95L and MR95LD with 1/4 NPT body size and 0.14 to 0.41 bar / 2 to 6 psi spring range.

✉ Webadmin.Regulators@emerson.com

Facebook.com/EmersonAutomationSolutions

🔍 Fisher.com

🌐 LinkedIn.com/company/emerson-automation-solutions

🐦 Twitter.com/emr_automation

Emerson Automation Solutions Regulator Technologies

Americas

McKinney, Texas 75070 USA
T +1 800 558 5853
+1 972 548 3574

Asia Pacific

Singapore 128461, Singapore
T +65 6770 8337

Europe

Bologna 40013, Italy
T +39 051 419 0611

Middle East and Africa

Dubai, United Arab Emirates
T +971 4 811 8100

D103587X014 © 2014, 2017 Emerson Process Management Regulator Technologies, Inc. All rights reserved. 01/17.

The Emerson logo is a trademark and service mark of Emerson Electric Co. All other marks are the property of their prospective owners. Fisher™ is a mark owned by Fisher Controls International LLC, a business of Emerson Automation Solutions.

The contents of this publication are presented for information purposes only, and while effort has been made to ensure their accuracy, they are not to be construed as warranties or guarantees, express or implied, regarding the products or services described herein or their use or applicability. All sales are governed by our terms and conditions, which are available on request. We reserve the right to modify or improve the designs or specifications of our products at any time without notice.

Emerson Process Management Regulator Technologies, Inc does not assume responsibility for the selection, use or maintenance of any product. Responsibility for proper selection, use and maintenance of any Emerson Process Management Regulator Technologies, Inc. product remains solely with the purchaser.



For further information on the current PED revision see Bulletin: [D103053X012](#) or scan the QR code.



The distinctive diamond shape cast into every spring case uniquely identifies the regulator as part of the Fisher™ brand and assures you of the highest-quality engineering, durability, performance, and support.

